

HM2170/HM2172

60fps ▪ 1/7" 1080p ▪ Color CIS

Ultra-Compact, Low-Noise FHD Sensor



Overview

HM2170 is an ultra-low power 60FPS 1080p (FHD) CMOS Image Sensor (CIS) featuring high performance 1.12 μ m Backside Illuminated (BSI) pixel technology that delivers excellent noise performance to support Skype® and Lync® video communication requirements.

The sensor's BSI pixels are optimized for high CRA lens to support low profile camera module. The tiny sensor package can support a camera module y-dimension of 3mm that enables thin bezel notebook design and small form factor IoT devices.

HM2170 consumes less than 110mW when operating at 60FPS and features sub-mW readout modes to enable Always-On Vision (AONV) modes for next-generation intelligent features such as Wake-On Human Approach. The sensor includes an embedded WOM (Wake-On-Motion) monitor that can generate an interrupt to wake up host processor while consuming less than 1mW.

Features

- High performance and low cost 60FPS FHD BSI Sensor
- Ultra-compact 4.5mm x 2.28mm CSP and RW package enables 3mm y-dimension camera module
- <110mW operating at 60FPS with 2 power supply and <100mW operating at 60FPS with 3 power supply
- Up to 8x channel and quad binning readout modes
- Sub-mW Always-On Vision (AONV) modes with motion detection, ambient light estimation, and programmable interrupts
- Quick mode switch between two preset modes
- Fast power up on, <50ms from power-up to start output well exposed frame
- 1/2-lane MIPI CSI2 interface with ULPS, SSCG and embedded data
- Dedicated Serial Data Interface (SDI) for CV processor that can run concurrently with video mode over CSI2
- Integrated OTP for module calibration and tracking
- Supports FHD 30FPS staggered dual exposure HDR video with separate long and short gain control (HM2172 only)

HM2170/HM2172

60fps ▪ 1/7" 1080p ▪ Color CIS ▪ HDR



Sensor Parameters

Active Pixel Array (Format)	1920 x 1080 (1/7.2")	
Pixel Size	1.12µm x 1.12µm	
Sensor Diagonal	2.48 mm diagonal	
Max. Frame Rate	HD 1080p	60 fps
Sensitivity (@ 530nm)	273 mV / Lux – sec	
SNR _{max}	35.42dB	
Dynamic Range	59.48dB	
Chief Ray Angle	34.43° non-linear	

General Specifications

Serial Interface	SDA, SCL	
Output Format	8/10 RAW	
Video Interface	2-lane MIPI CSI2	
PLL Input Frequency Range	6 – 48MHz	
Supply Voltage	AVDD / DVDD	2.8V / 1.2V
	IOVDD	1.8V / 2.8V
Power Consumption	FHD 30fps	105mW
	480x270@ 2fps (SDI output)	2mW
	Event Detection	1.48mW

Block Diagram

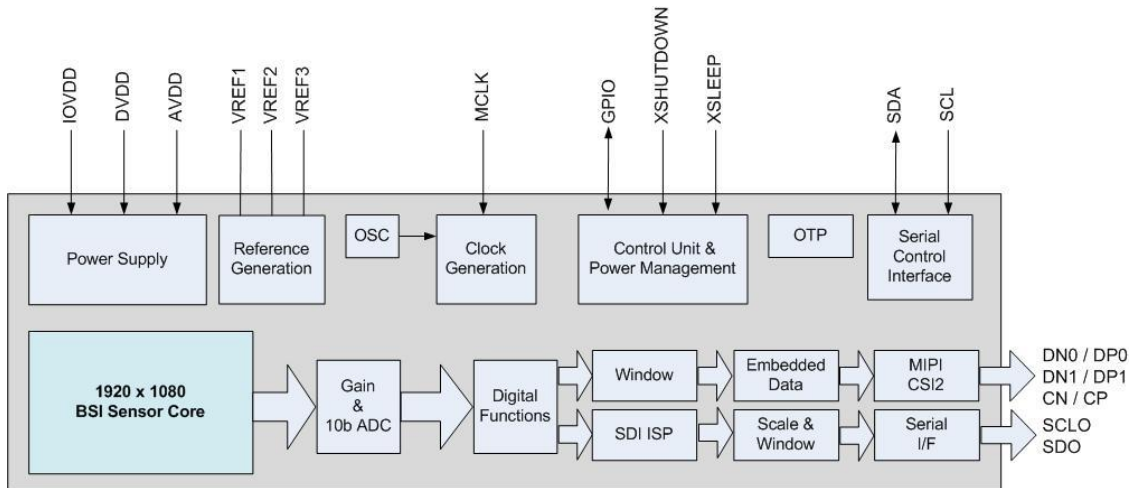

Order Information

Part Number	Color Option	Operating / Storage Temperature	Package
HM2170-AWA/HM2172-AWA	RGB	-20C to 70C / -40C to 85C	CSP
HM2170-AGA/HM2172-AGA	RGB	-20C to 70C / -40C to 85C	Bare Die (RW)

About Himax Imaging

Himax Imaging designs CMOS sensors for a wide range of consumer camera applications. Our vision is to provide cost competitive CMOS sensors that are designed for performance and simplicity. The company is based in Hsinchu, Taiwan, with offices in United States, China and Korea. Please contact our experienced Sales team for additional information about the company and our products. Visit us at www.himax.com.tw.

The information appearing in this publication is believed to be accurate and reliable. However, Himax Imaging makes no warranty for any errors which may appear in this document. The following are trademarks of Himax Imaging Incorporated: Himax Imaging, BrightSenseHS, ClearView, the Himax Imaging logo symbol. All other trademarks are the properties of their respective owner.

North America (U.S.A)

36 Discovery, Suite 270
Irvine, Ca 92618
+1 949 585 9838

Taiwan

17F, No. 285, Section2, Guangfu Road
Hsinchu 30071, Taiwan (R.O.C.)
+886 3 516 3277

Contact Information

hi_sales@himaximaging.com
hi_marketing@himaximaging.com
hi_fae@himaximaging.com

©2024, Himax Imaging Corporation, All Rights Reserved.

This information contained herein is the exclusive property of Himax Imaging and shall not be distributed, reproduced, or disclosed in whole or in part without prior written permission of Himax Imaging. **This document is subject to change without notice.**

- P.2 -
Rev 0.1